

PRECISION STAMPINGS, INC.
 500 EGAN AVE. BEAUMONT, CA. 92223 (951)845-1174
 CAD FILE=16940-01 LAYER=APP-M-*

DIMENSIONS IN INCHES
 UNLESS OTHERWISE SPECIFIED

TOOLING DETAIL DESCRIPTION
 PSI BANDOLLIER ϕ .040
 .500" - 1.500" LENGTH
 COMPANY/PRODUCT
 PSI (ϕ .040 BANDOLLIER ROUND WIRE)
 DRAWING# 16940-01
 TOOL = BANDOLLIER SHEET# 1 OF 2

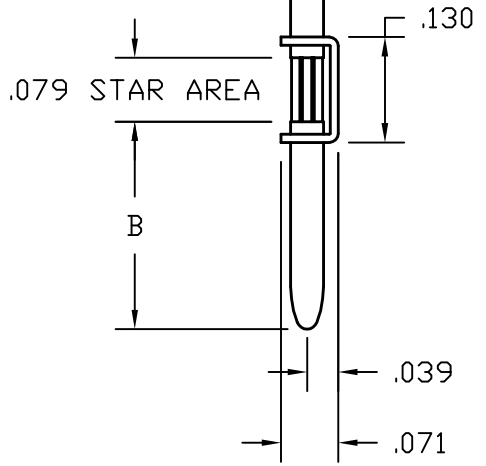
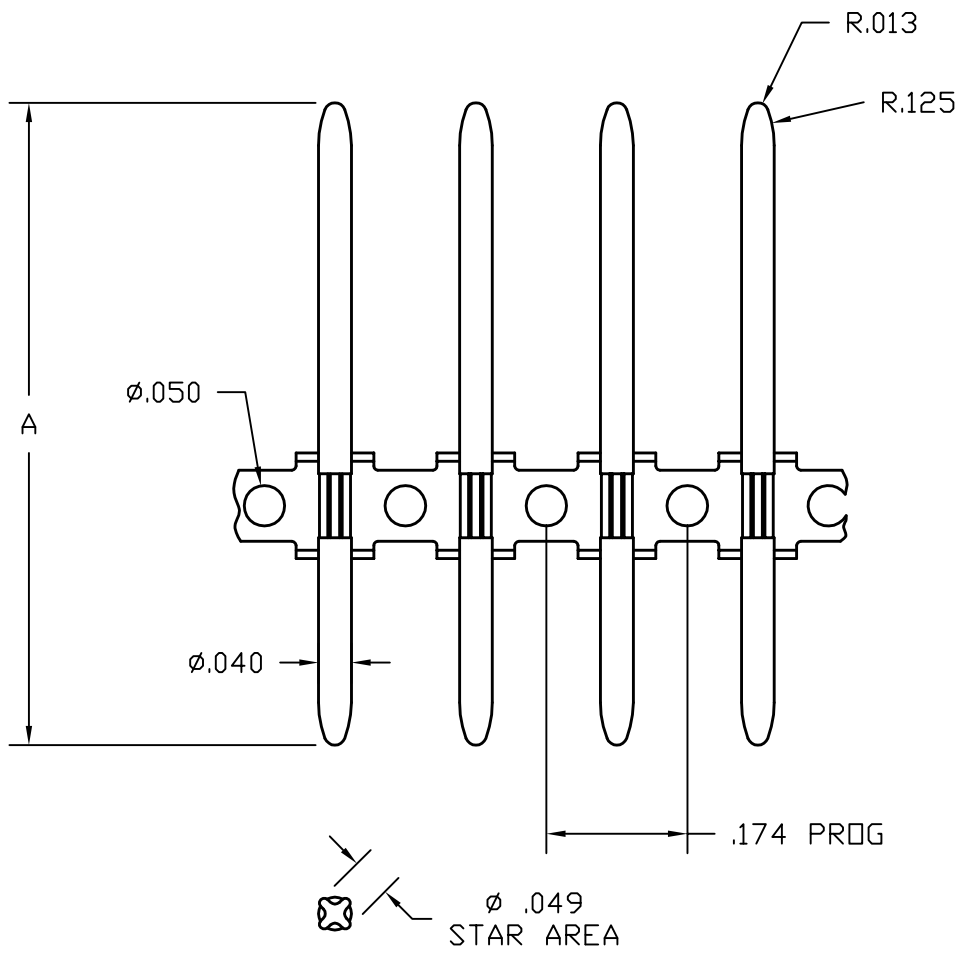

A = .500" MIN TO 1.500" MAX
 B = .150" MIN TO 1.250" MAX

MATERIAL:
 BAND = C260 BRASS 1/2 HARD .010 THICK
 WIRE = SEE SHEET 2

'A' 4-19-10	'A' 4-19-10	INITIAL RELEASE	BLS
'TOOL' REV-DATE	'PRODUCT' REV-DATE	DESCRIPTION/REMARKS	INITIALS

PRECISION STAMPINGS, INC.
 500 EGAN AVE. BEAUMONT, CA. 92223 (951)845-1174
 CAD FILE=16940-01 LAYER=APP-M-*

DIMENSIONS IN INCHES
 UNLESS OTHERWISE SPECIFIED

TOOLING DETAIL DESCRIPTION
 PSI BANDOLLIER ϕ 0.040
 .500" - 1.500"
 COMPANY/PRODUCT
 PSI ϕ 0.040 BANDOLLIER ROUND WIRE
 DRAWING# 16940-01
 TOOL = BANDOLLIER SHEET# 2 OF 2

WIRE MATERIAL:

ϕ .040

- | | | |
|-----------------|-----------------|---------------|
| C102 ANNEALED | C510 ANNEALED | C725 ANNEALED |
| C102 HARD | C510 1/4 HARD | C725 1/4 HARD |
| C102 SPRING | C510 1/2 HARD | C725 1/2 HARD |
| | C510 3/4 HARD | C725 3/4 HARD |
| C110 ANNEALED | C510 HARD | C725 HARD |
| C110 HARD | C510 SPRING | C725 SPRING |
| C110 SPRING | | |
| C151 ANNEALED | C521 ANNEALED | C752 ANNEALED |
| C151 1/4 HARD | C521 1/4 HARD | C752 1/4 HARD |
| C151 1/2 HARD | C521 1/2 HARD | C752 1/2 HARD |
| C151 HARD | C521 3/4 HARD | C752 HARD |
| C151 SPRING | C521 HARD | C752 SPRING |
| | C521 SPRING | |
| C172 ANNEALED | C638 ANNEALED | |
| C172 1/4 HARD | C638 1/4 HARD | |
| C172 1/2 HARD | C638 1/2 HARD | |
| C172 3/4 HARD | C638 3/4 HARD | |
| C172 HARD | C638 HARD | |
| C172 EXTRA HARD | C638 EXTRA HARD | |
| C172 SPRING | C638 SPRING | |
| C197 ANNEALED | C655 ANNEALED | |
| C197 1/4 HARD | C655 1/4 HARD | |
| C197 1/2 HARD | C655 1/2 HARD | |
| C197 3/4 HARD | C655 HARD | |
| C197 HARD | C655 SPRING | |
| C197 SPRING | | |
| C260 ANNEALED | C7025 ANNEALED | |
| C260 1/4 HARD | C7025 1/2 HARD | |
| C260 1/2 HARD | C7025 HARD | |
| C260 3/4 HARD | | |
| C260 HARD | C710 ANNEALED | |
| C260 EXTRA HARD | C710 1/4 HARD | |
| C260 SPRING | C710 1/2 HARD | |
| | C710 HARD | |
| | C710 SPRING | |

'A' 4-19-10	'A' 4-19-10	INITIAL RELEASE	BLS
'TOOL' REV-DATE	'PRODUCT' REV-DATE	DESCRIPTION/REMARKS	INITIALS